



Standard Test Method for Spontaneous Heating Values of Liquids and Solids (Differential Mackey Test)¹

This standard is issued under the fixed designation D3523; the number immediately following the designation indicates the year of original adoption or, in the case of revision, the year of last revision. A number in parentheses indicates the year of last reapproval. A superscript epsilon (ϵ) indicates an editorial change since the last revision or reapproval.

1. Scope

1.1 This test method covers the non-adiabatic determination of the spontaneous heating values (SHV) of liquids and solids. It is applicable to substances that are not completely volatile at the test temperature. Spontaneous heating values obtained by this test method are qualitative indications of the degree of self-heating that may be expected to occur upon exposure of the sample to air at the test temperature.

1.2 Values obtained by this method are applicable to liquids and solids supported on cellulosic surfaces. They are not applicable to liquids on metal surfaces, on contaminated surfaces, or at pressures above atmospheric.

1.3 Spontaneous heating values determined by the present test method are regarded only as qualitative measurements of self-heating which occurs under the conditions of the test. The test method does not purport to produce a quantitative measure of the enthalpy of reaction of the sample with air at a given test temperature. Such data can be obtained by the use of an adiabatic calorimeter. The existence, under the test conditions, of a positive temperature difference between the sample and the reference is evidence of a thermochemical reaction in the sample.

1.4 The magnitude of the measured temperature difference is a semiquantitative indication of the enthalpy and rate of that reaction. Since factors such as heat loss from the sample to the bath and quenching of the reaction due to too rapid consumption of oxygen affect the amount and duration of the measured heat effect, care must be taken not to attribute too much quantitative significance to the test results. It is sufficient, for the purpose of this test, to determine whether or not the sample is capable of undergoing a self-heating reaction of sufficient magnitude and rapidity to produce a detectable thermal effect. The spontaneous heating value (SHV) can be lower than the

test temperature. A negative result does not preclude spontaneous heating initiating at a temperature higher than the test temperature.

1.5 This standard should be used to measure and describe the response of materials, products, or assemblies to heat and flame under controlled conditions and should not be used to describe or appraise the fire-hazard or fire-risk of materials, products, or assemblies under actual fire conditions. However, results of this test may be used as elements of a fire-hazard assessment or a fire-risk assessment which takes into account all of the factors which are pertinent to an assessment of the fire hazard or fire risk of a particular end use.

1.6 The values stated in SI units are to be regarded as the standard. In cases where materials, products or equipment are available in inch-pound units only, SI units are omitted.

1.7 *This standard does not purport to address all of the safety concerns, if any, associated with its use. It is the responsibility of the user of this standard to establish appropriate safety and health practices and determine the applicability of regulatory limitations prior to use.*

2. Referenced Documents

- 2.1 *ASTM Standards*:²
[D1193 Specification for Reagent Water](#)

3. Terminology

3.1 Definitions of Terms Specific to This Standard:

3.1.1 *spontaneous heating value (SHV)*—the maximum amount by which the temperature of the sample exceeds that of the reference when exposed at a given temperature in the standard apparatus.

3.2 Symbols:

t_S = temperature of sample side at any time during test, K,
 t_R = temperature of reference side at time t_S is measured, K,

¹ This test method is under the jurisdiction of ASTM Committee D02 on Petroleum Products, Liquid Fuels, and Lubricants and is the direct responsibility of Subcommittee D02.L0.07 on Engineering Sciences of High Performance Fluids and Solids (Formally D02.1100).

Current edition approved April 15, 2012. Published April 2012. Originally approved in 1976. Last previous edition approved in 2007 as D3523–92(2007). DOI: 10.1520/D3523-92R12.

² For referenced ASTM standards, visit the ASTM website, www.astm.org, or contact ASTM Customer Service at service@astm.org. For *Annual Book of ASTM Standards* volume information, refer to the standard's Document Summary page on the ASTM website.

- T_S = maximum temperature of sample chamber during test, K,
- T_R = temperature of reference chamber measured at same time that T_S is measured, K,
- Δt = $t_S - t_R$,
- ΔT = $T_S - T_R$,
- B_R = equilibrium temperature of reference side during blank run, K,
- B_S = equilibrium temperature of sample side during blank run, K,
- ΔT_B = $B_S - B_R$ = instrumental blank,
- Δt_C = $\Delta t - (B_S - B_R) = \Delta t - \Delta T_B$, and
- ΔT_C = $\Delta T - (B_S - B_R) = \Delta T - \Delta T_B$ = spontaneous heating value.

4. Summary of Test Method

4.1 The sample is supported on surgical gauze and placed in a heated chamber which is open to the air at the top. The temperature of the sample, thus prepared, is compared to that of an equal reference quantity of surgical gauze contained in an identical chamber. The amount by which the temperature of the sample exceeds that of the reference is taken as an index of the spontaneous heating value of the sample. Tests may be conducted for durations of 4 to 72 h or longer if desired.

4.1.1 Any convenient, inert, fibrous substrate of adequate absorbency may be substituted for surgical gauze as required. Any such substitution shall be reported with the spontaneous heating value so obtained.

5. Significance and Use

5.1 The spontaneous heating value of a substance is a measure of the ability of that substance to undergo self-heating reactions while supported by cellulosic or other fibrous material in air. It is an index of the autoignition tendency of the substance under such conditions.

6. Apparatus

- 6.1 *Spontaneous Heating Apparatus*—See Fig. 1 and Fig. 2.
- 6.2 *Thermocouples*, 30-gage, iron-constantan, Type J. Two are required.
- 6.3 *Strip Chart Temperature Recorder*, two-channel or multipoint, capable of 0.5 K resolution at test temperature.
- 6.4 *Hot Plate*, capable of uniformly heating entire bottom surface of spontaneous heating apparatus.

7. Materials

- 7.1 *Cotton Gauze*, surgical.
- 7.2 *Water*, conforming to Specification D1193, Type III.

8. Procedure

8.1 *Determination of Instrumental Blank:*

8.1.1 Assemble the spontaneous heating apparatus and place 2000 mL of distilled water in the boiling chamber. Heat the apparatus until continuous refluxing occurs.

8.1.1.1 When test temperatures higher than that obtained by the refluxing of water in the test apparatus are desired, reagent grade ethylene glycol or any other suitable pure compound may be substituted for water. Report any such substitutions with the test data.

8.1.2 Pack the sample and reference containers (screen baskets) with 20 g of rolled cotton gauze. Insert a thermocouple in the center of the gauze mass in each container and place both in the apparatus.

NOTE 1—When considerable variation in temperature from the norm exists, an additional thermocouple may be necessary to measure the temperature of the bath.

8.1.3 Allow the system to attain thermal equilibrium and then continue heating for 4 h. Record temperature readings, B_R

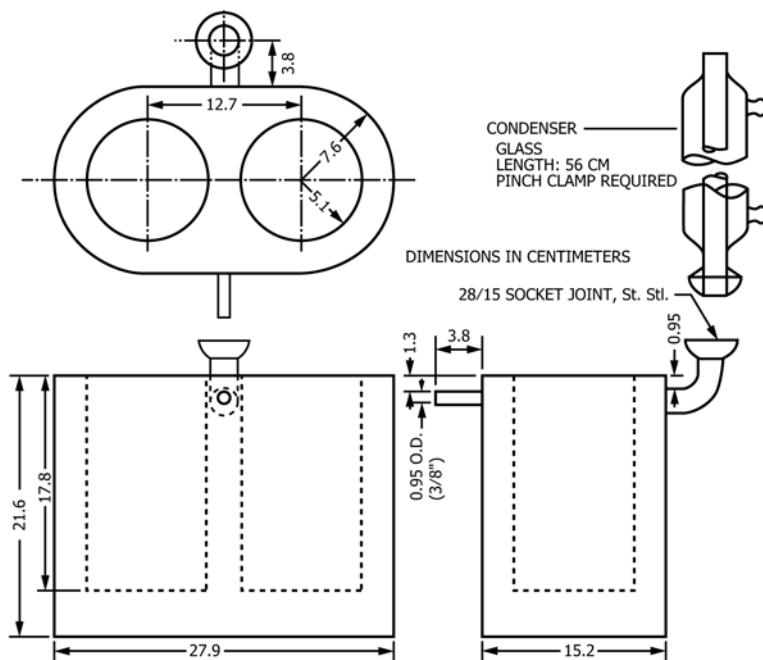

FIG. 1 Spontaneous Heating Apparatus (Copper Body)